

Model		M878.6±0.5-120-D200/22-C2A		
Optical Parameters	Unit	Min	Typical	Max
Output Power	W		120	
Central Wavelength	nm		878.6	
Wavelength Tolerance	nm		± 0.5	
Spectral Width (FWHM)	nm		<0.5	
Wavelength Temp. Coefficient	nm/°C		0.02	
Wavelength Current Coefficient	nm/A		0.05	
Fiber Parameters				
Fiber Core Diameter	µm		200	
Fiber Cladding Diameter	µm		220	
Numerical Aperture			0.22	
Bare Fiber Length	m		2 or customized	
Fiber connector (optional)	-		SMA905	
Electric Parameters				
Threshold Current	A		1.5	
Operating Current	A		11.8	13.0
Operating Voltage	V		21.1	24.0
Slope Efficiency	W/A		11.8	
Power Conversion Efficiency	%		48	
Back Reflection Protection				
Wavelength range	nm		1030 – 1100	
Attenuation	dB		>40	
Other Parameters				
Operating Temperature (Thermistor)	°C		25 – 35	
Operating Humidity	%		< 75	
Storage Temperature	°C		-20 – +80	

Pinout	Function
1	Laser Diode Cathode
2	Laser Diode Anode
3	NC
4	NC
5	Photodiode Cathode
6	Photodiode Anode
7	Thermistor
8	Thermistor

Compliance with Regulatory Requirements: This industrial laser is an OEM version of a laser diode. As such, it is intended only for integration into other equipment. This laser does not comply with IEC and CDRH requirements. The customer is responsible for IEC and CDRH certifications of the system that incorporates this industrial laser.

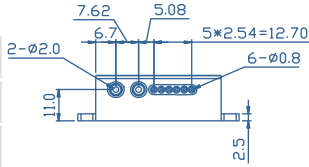
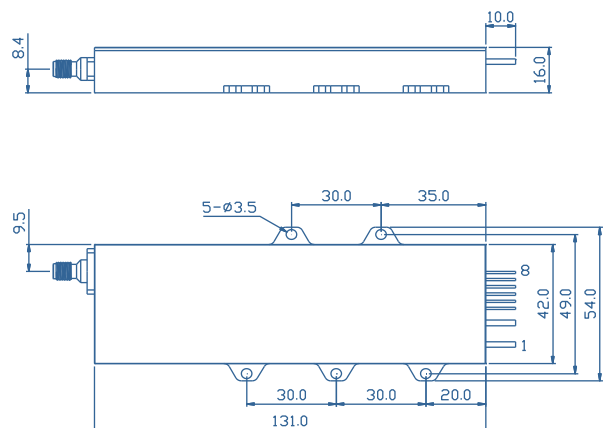